

NEW
RENAULT
MASTER E-TECH
100 % electric



also available in diesel

July 2024



aerovan generation

Designed in a wind tunnel and completely reshaped, the new Renault Master is ushering in a new era for commercial vehicles by becoming the aerovan. Aerodynamics and technologies for efficiency, connectivity with Google⁽¹⁾ built in, assisted driving and great user comfort.



available with E-Tech 100% electric and diesel engines, the new Renault Master helps you meet all your professional challenges.

wide range of converted vehicles through our approved suppliers

up to 1,625 kg of payload⁽²⁾

up to 285 miles of driving range⁽²⁾⁽³⁾ with 100% electric E-Tech

openR link multimedia system with Google built-in⁽¹⁾

dynamic braking system

20 advanced driver-assistance systems

(1) Available as an option on Advance versions, standard on Extra versions. My Renault, Google Maps and Google Assistant connected services are provided free of charge for 5 years from the date of delivery of your vehicle. Google, Google Maps, Google News, Waze and other brand names are all trademarks of Google LLC. (2) in L2H2 E-Tech 100% electric version – 87 kWh – 4 tonnes. (3) measurement at the socket in the WLTP cycle.

interactive menu

01. design

02. interior experience

03. loading

04. multimedia

05. engines

06. range and charging

07. converted versions

**08. advanced driving
assistance systems**

09. customisation

high-performance design

The tilt of the windscreen, the air intakes, the shape of the wing mirrors and the streamlined design of the rear area: all the key design elements have been optimised to enhance the vehicle's aerodynamic performance.



Drawing inspiration from American trucks, the robust styling of the grille incorporating the new Renault emblem gives it a powerful personality.



a driver oriented cockpit

The interior combines an innovative driving position with a high level of working comfort: wrap-around individual seats, driver-oriented S-shaped dashboard for easy-to-access controls.



Enjoy workspace focused on your needs: mobile office with connectivity, USB-C* and 12V sockets, reinforced upholstery covering for optimised durability.



With nine storage areas with a total capacity of 135L, the new Renault Master is among the market's leading vehicles that will enable you to stay optimally organised.



66-litre storage compartment under front passenger seats

*optional

03. loading

optimal loading

**Best-in-class loading performance:
up to 1,625kg⁽¹⁾⁽²⁾ of payload and
2.5 tonnes of towing capacity.**



**And also the best sliding side
opening in its category with
1,312mm⁽²⁾, rear doors that open
at 270°⁽³⁾ and the foot step⁽³⁾
of the new Renault Master provide
easy access to the loading area.**



(1) on the L2H2 E-Tech 100% electric version – 87 kWh – 4 tonnes. (2) van version, Large Van category. Renault study of 27/10/2023. (3) 270 degree opening doors and rear step available as an optional.

menu

openR link multimedia system with Google built-in⁽¹⁾

Enjoy a 10" screen equipped with the openR link multimedia system and the Google built-in option⁽¹⁾. A fluid and intuitive interface that supports you on all your business trips.



Access all the Google tools and services you need. With Google Maps⁽¹⁾, get numerous features: continuous updates, real-time traffic, information about points of interest, etc.



Using Google Assistant⁽¹⁾, manage your journeys, your communications or the temperature on board by voice control, without compromising your driving experience.



Choose from more than 50 apps: manage your parking with EasyPark, listen to music with Amazon Music or check your emails with the Vivaldi browser.



Waze is a community-based navigation app that shares information in real time. Waze boosts your peace of mind.



Take to the road while listening to playlists, and much more, with **Amazon Music**, included with your Amazon Prime subscription.



Vivaldi browser is an efficient, fast web browser that respects your privacy.



With **EasyPark**, plan and book millions of parking spaces across Europe. Enter your destination's address or navigate using the map.

⁽¹⁾ standard on Extra trim level and option on Advance. My Renault, Google Maps and Google Assistant connected services are provided free of charge for 5 years from the date of delivery of your vehicle. Google, Google Maps, Google News, Waze and other marks are trademarks of Google LLC.

applications for professionals

In partnership with specialists, New Renault Master offers a customised solution for professionals thanks to the openR link with convertor companion⁽¹⁾ option, which allows you to manage the specific features of your converted vehicle directly from the 10" screen.



TIB application

Designed for fire brigade vehicles, it can be used, for example, to control the exterior and interior lighting, or open and close the doors; it can also provide battery status.

Lamberet application

Designed for refrigerated vehicles, it is used for temperature management, and can let you know if they are registered.

Modul System application

For workshop vehicles, it automatically calculates loading (among other things) and lets you know if you are overloading your vehicle.

(1) optional.

My Renault connected services

With the My Renault application, manage your vehicle remotely easily via your smartphone: unlocking alert, vehicle location, remote activation of the lights and horn.



Make everyday life easier with the My Renault application

organise your journeys

- plan your journey, automatically adding stops at petrol stations / charging stations
- locate your vehicle at any time
- find your vehicle by activating the horn and lights

control your E-Tech 100% electric version

- check in real time the level of charge and driving range of your battery
- Remotely programme and manage your charging and cabin temperature
- locate the public charging points nearest to you

view your vehicle's finer details

- discover all the features of your vehicle thanks to our video tutorials and vehicle instructions
- find your service contracts and warranty extensions
- access our store to find services and accessories for your vehicle

manage your vehicle's maintenance

- access your maintenance history and receive alerts for upcoming services
- make an appointment in the workshop
- benefit from customised Renault offers

at the forefront of innovation

New Master offers a range of diesel and E-Tech 100% electric engines: 3 Blue dCi powers and an electric battery to meet the needs of business customers.



Drive more than 620 miles⁽¹⁾ with the new innovative Blue dCi engine with reduced CO₂ emissions and lower fuel consumption⁽²⁾. This diesel version is also available with the all-new 9-speed automatic gearbox.



The New Renault Master offers a comfortable and safe braking experience: identical efficiency regardless of the loading weight and reaction time reduced by half during emergency braking⁽³⁾. In electric vehicles, the regenerative power of the new system and its reduced weight help extend your range.



(1) Blue dCi 2L, combined cycle WLTP standard. (2) when comparing New Renault Master to previous versions of Renault Master. (3) if triggered by a driver assistance system.

06. range and charging

up to 285 miles of range⁽¹⁾⁽²⁾

With no CO₂ emissions, the 100% electric E-Tech version helps you during your daily urban trips and ensures you can access low-emission zones.



The progress achieved by optimising aerodynamics and the all-new platform combined with the dynamic braking system reduce electric consumption by 27%⁽³⁾.

The 87kWh battery provides a range of up to 285 miles and comes with 22kw AC and 130 DC charging as standard.

aerodynamic design

The new lines of the Renault Master E-Tech 100% electric have been designed to maximise its driving range: tilted windscreen, air intakes, the shape of the door mirrors and the streamlined rear section.

dynamic braking system

This all-new compact system delivers the same braking efficiency regardless of the load weight and reduces reaction time in emergency braking by half. Each deceleration recovers energy and improves the overall range of the vehicle on 100% electric E-Tech versions.

low-consumption tyres

Their low rolling resistance helps to preserve driving range without adversely affecting road holding or braking quality.

range

87 kWh battery:
· up to 285 miles⁽¹⁾⁽²⁾ of range

(1) on the L2H2 E-Tech 100% electric version – 87 kWh – 4 tonnes. (2) measurement at the socket in the WLTP cycle. (3) measurement at the socket in the WLTP cycle compared New Renault Master L2H2 E-Tech 100% electric 87 kWh versus Renault Master E-Tech 100% electric 52 kWh. Internal Renault study (4) Approval in progress.

06. range and charging

easy to charge

At home, at work or on the move, new Renault Master E-Tech 100% electric offers you a versatile range of charging solutions.



on-street charging

DC rapid charge⁽¹⁾ 130 kW maximum

For longer journeys, get up to 285 miles⁽²⁾⁽³⁾ of WLTP range in 1 h 10 from a DC rapid charging station.

My Renault application

Locate and check the availability of public charging stations. Pay for your charging using the built-in Charge pass⁽⁴⁾.

Mobilize business pass

With the Mobilize business pass designed for business use, recharge your fleet vehicles at Mobilize Power Solutions charging stations at work, at home and on the public grid.

charging at work, at home or elsewhere

AC charging⁽⁵⁾ 22 kW as standard



Charge your new Renault Master E-Tech 100% electric on the domestic network with a wall-mounted charging point, a reinforced socket, or, for occasional charging, a standard domestic socket.

Mobilize power solutions

Take advantage of a range of terminals and sockets best adapted to your needs and get support installing and using them.

(1) direct current. (2) on the L2H2 E-Tech 100% electric version - 87 kWh - 4 tonnes. (3) measurement at the socket in the WLTP cycle. (4) subject to subscribing to the service. (5) alternating current.

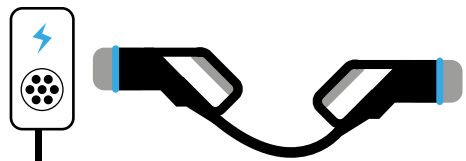
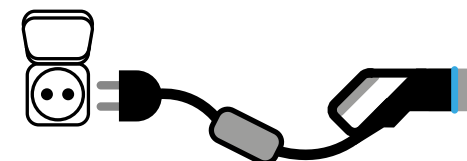
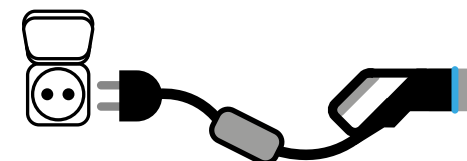
New Renault Master E-Tech 100% electric is delivered with a mode 3-type cable that can be used with a domestic⁽¹⁾ or public charging station.

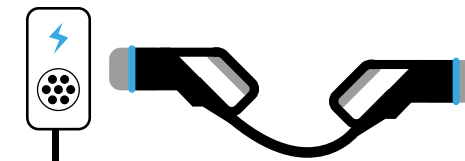
domestic			public	
domestic charging station⁽¹⁾ 7.4 kW	reinforced domestic socket 3.7 kW	standard domestic socket⁽²⁾ 2.3 kW	public fast charging point 150 kW	public charging station 22 kW
mode 3 cable included with purchase	standard mode 2 or optional flexi-charger cable	optional mode 2 flexi-charger cable	cable attached to station	mode 3 cable included with purchase
				

87kWh battery⁽³⁾ for a maximum range of 285 miles⁽⁵⁾⁽⁶⁾

31 miles → 1 h 55	31 miles → 3 h 55	31 miles → 6 h 28	31 miles → 6 min	31 miles → 38 min
112 miles → 5 h 44	112 miles → 11 h 46	112 miles → 21 h 59	112 miles → 19 min	112 miles → 1 h 53
286 miles → 13 h 54	286 miles → 28 h 30	286 miles → 47 h 02	286 miles → 1 h 10	286 miles → 4 h 35

For more information on Mobilize power solutions offering please visit business.renault.co.uk/master-range/renault-master/recharge (2) only for occasional use. (3) connected to a 150kW public fast charging station. The charging times shown are calculated under optimal conditions for the battery, temperature values and charging stations. These times vary depending on the versions, options and programming of the vehicle. The distances are measurements based on the WLTP protocol. (4) approval in progress. (5) on the L2H2 E-Tech 100% electric version – 87 kWh – 4 tonnes. (6) measurement at the socket in the WLTP cycle.

your tailor-made utility vehicle

Renault provides a range of converted products through our industrial conversion facility at the Batilly plant and via our approved network of local converters partners.



From crew vans to box vans to transport goods and people, to dropsides and tippers for construction, platform and chassis cabs for conversion, there is a new Renault Master for every activity sector.



double-cab chassis versions

Renault works with over 40 certified converters in the UK who can deliver everything from refrigerated vans to horseboxes.



single cab tipper version

08. advanced driving assistance systems



20 advanced driver-assistance systems

As part of the human first program, Renault Master comes with 20 advanced-technology systems to ensure your safety and that of your passengers.



rear view camera

Via a digital screen – instead of the interior rear-view mirror – you can view what the camera installed at the rear of your vehicle captures*.



rear parking sensors

Radar sensors facilitate your manoeuvres by warning you with audio and visual signals of the proximity of obstacles in front of or behind the vehicle.



automatic emergency braking with pedestrian/cyclist detection

Using a sensor, it detects pedestrians and cyclists coming from ahead or from the side, and prompts the driver to brake if there is a risk of collision. The system brakes harder if it detects that the driver has reacted too slowly, and can bring the vehicle to a complete stop if necessary**.

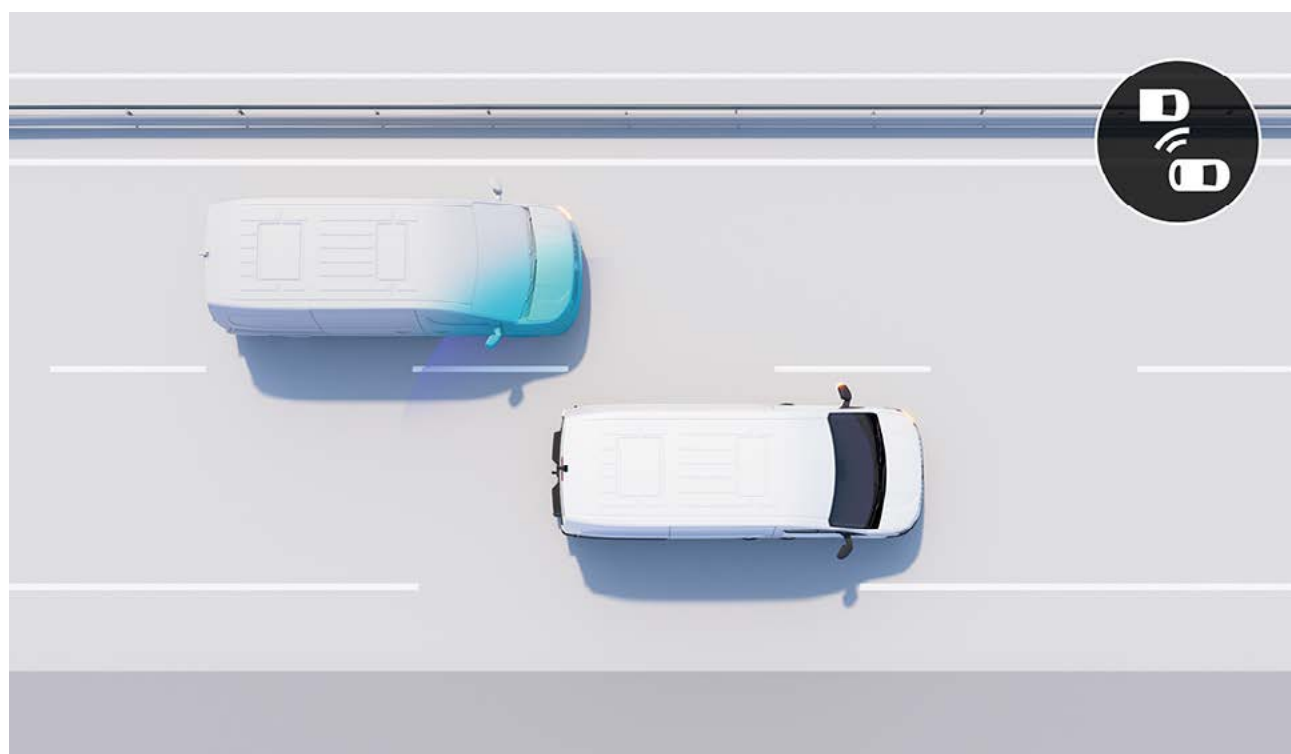

blind spot warning

It can detect the presence of a cyclist or a vehicle in the rear side areas outside the field of visibility. A warning light in the door mirrors alerts the driver. On the passenger side, a radar detects cyclists in the blind spot on the passenger side and triggers an audible light signal*.

driving assistance systems

- rear view assist*
- automatic main/dipped beam headlight activation*
- road sign recognition and speeding alert

park assist systems

- front parking sensors*
- rear parking sensors
- side parking sensors*
- rear view camera*

safety assistance systems

- anti-lock braking system
- blind spot warning*
- automatic emergency braking
- automatic emergency braking with pedestrian/cyclist detection

*optional. ** Pedestrian/cyclist on MM40 and LM40 only.

09. customisation

colours



agave blue⁽¹⁾



tempest⁽²⁾



star grey⁽²⁾



pearl black⁽²⁾



mineral white⁽¹⁾



urban grey⁽¹⁾



energy red⁽¹⁾

(1) solid non-metallic.
(2) metallic.

09. customisation

interior trims



advance

- 3.5" black and white TFT display
- 7" colour TFT driver information display (E-Tech only)
- front LED lights with C-shaped signature
- dynamic braking system
- automatic headlights and wipers
- 10" openR link multimedia system
- 12 V socket in central console
- manual air conditioning
- dark marl fabric upholstery with dark grey stitching



extra (advance+)

- 16" steel wheel rims with large wheel covers
- 10" openR link multimedia system with Google built-in⁽¹⁾
- grey marl fabric upholstery with blue stitching

(1) available as an option, depending on the version. My Renault, Google Maps and Google Assistant connected services are provided free of charge for 5 years from the date of delivery of your vehicle. Google, Google Maps, Google News, Waze and other brand names are all trademarks of Google LLC.

09. customisation

upholstery



dark grey marled fabric upholstery and reinforced driver seat side in grained coated textile⁽¹⁾



grey marled fabric upholstery with blue top-stitching and reinforced driver seat side in grained coated textile⁽²⁾

hubcaps and wheel rims



16" steel wheel rim extended vango protection⁽¹⁾



16" steel wheel rims airna hubcap

(1) standard on advance. (2) standard on extra and E-Tech 100% electric versions.

06. customisation

accessories

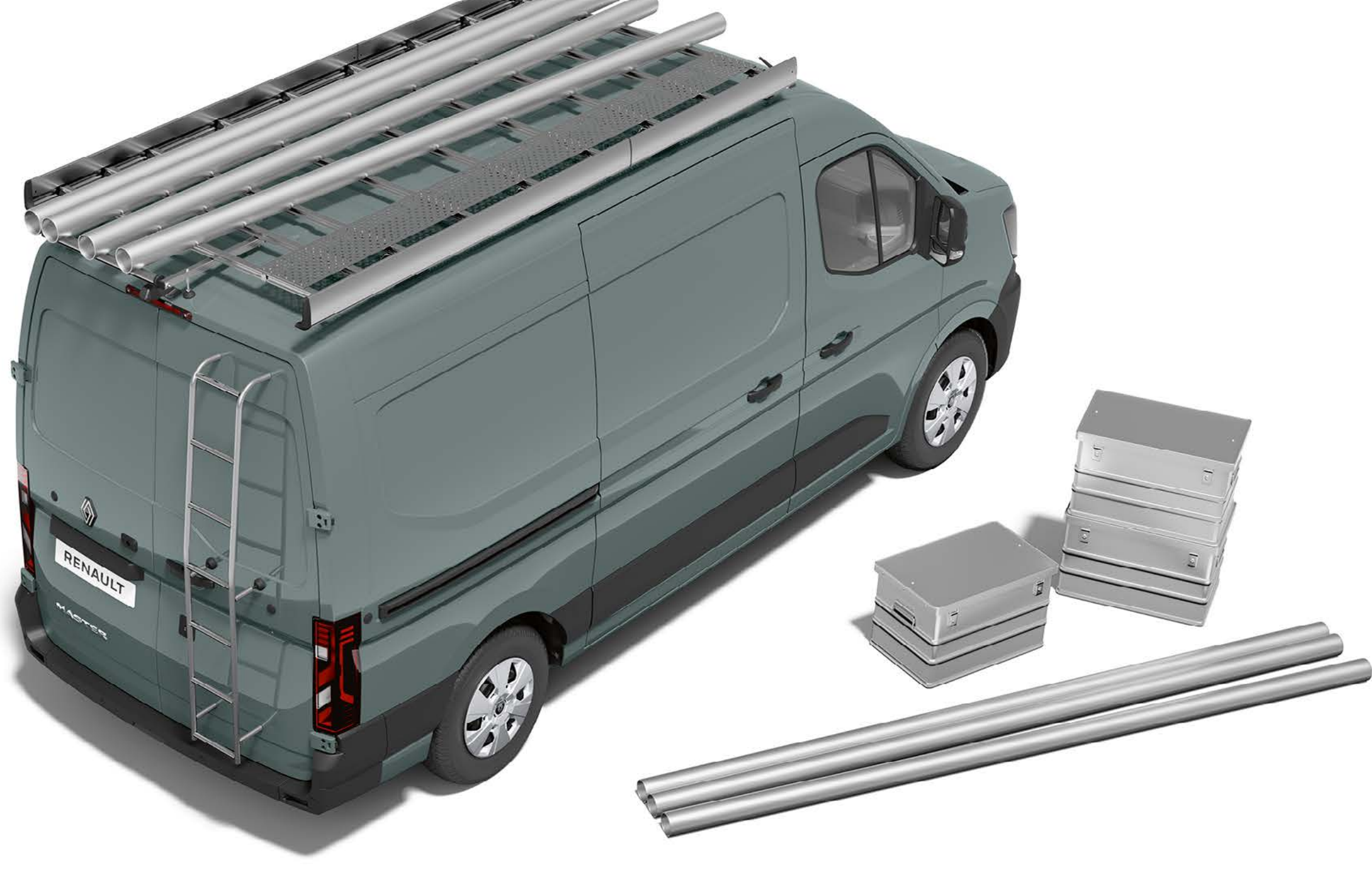

roof rack, walkway and a ladder

Equip your new Renault Master with the aluminium roof rack that can carry up to 150 kg of additional load. Used in conjunction with a walkway and ladder, it is everything you need for transporting bulky equipment safely.



roof bars

Ideal for increasing the vehicle's loading capacity. This official Renault accessory meets requirements well above safety and resistance standards.



standard towbar with ball joint

Easy to attach, use it to safely tow trailers and professional equipment. Perfectly compatible with the vehicle, it will not damage the body in any way. Intended for intensive use and a multiplicity of uses.



front and rear mud guards

Effectively protect the sill panel against mud splashes and grit.



rubber floor mats

Protect your cabin floor with these heavy-duty floor mats. Waterproof and easy to maintain, they can be quickly attached using the special safety clips provided.

STANDARD

Wall & side thickness	5.5mm	Small van	30kg
Floor & arch thickness	9mm	Medium van	50kg
Core type	Hard	Large van	75.6kg
Trim type	Aluminium		
Durability rating	★★★★★		
Waterproof	No		

BUBBLECORE LIGHTWEIGHT LINING

Wall & side thickness	4mm	Small van	15.3kg
Floor & arch thickness	10mm	Medium van	25kg
Core type	Polypropylene	Large van	37.8kg
Trim type	Premium aluminium		
Durability rating	★★★★★		
Waterproof	Yes		

PREMIUM - PLY SIDES & UPGRADED FLOOR

Wall & side thickness	5.5mm	Water-resistant	Yes
Floor & arch thickness	9mm	Small van	31.4kg
Core type	Hard	Medium van	51.4kg
Trim type	Aluminium	Large van	76.7kg
Durability rating	★★★★★		
Floor type	Anti-Slip Phenolic Resin Plywood Floor		

ply lining

Choose our Ply Lining to increase the practicality of your new Van. Available in Standard, Premium + Bubblecore. For fitment at our Import Centre.

09. customisation

E-Tech engines

100% electric	
max. power kW EEC (hp)	
105(140)	
max. torque EEC-Nm	
300	
battery	
storage capacity (kWh)	
87	
WLTP range (km)⁽¹⁾	
255 miles (N1) 285 miles (N2) ⁽³⁾	
type of charger	
22 kW AC with DC 130	
performance	
top speed (mph)	
120	
certification protocol	
WLTP ⁽¹⁾	

(1) WLTP (Worldwide Harmonised Light Vehicle Test Procedures): this new protocol provides results much closer to those found in daily use compared with the NEDC protocol.

(2) approval in progress.

(3) on the L2H2 E-Tech 100% electric version – 87 kWh – 4 tonnes. According to WLTP combined cycle standard.

internal combustion engines

Euro 6^e			
Blue dCi 130	Blue dCi 150	Blue dCi 150 automatic gear box	Blue dCi 170 automatic gear box
gearbox			
6-speed manual gearbox	6-speed manual gearbox	automatic/9-speed ⁽¹⁾	automatic/9-speed ⁽¹⁾
peak power kW EEC (hp) at rpm			
96 (130) at 3 500	110 (150) at 3,500	110 (150) at 3,500	125 (170) at 3500
peak torque Nm EEC at rpm			
350 at 1,500	360 at 1,500	360 at 1,500	380 at 1,500
bodywork type			
all types of bodywork			
yes			
panel vans, chassis cabs, platform cabs, dropsides, tippers, luton low loaders and luton box vans			
yes			



Every precaution has been taken to ensure that the contents of this brochure were accurate and up-to-date at the time of publication. This document has been created using pre-production and prototype models. In line with its policy of continuous product improvement, Renault reserves the right to modify the specifications, vehicles and accessories described and featured at any time. Any such modifications are communicated to Renault dealers as quickly as possible. Depending on the country of sale, versions may differ and some equipment may be unavailable (standard, optional or accessory). Please contact your nearest dealer for the latest information. For reasons to do with the medium, the colours featured in this document may differ slightly from those of the actual paintwork or interior trim. All rights reserved. Reproduction in any format and by any means of all or part of this brochure is prohibited without prior written authorisation from Renault.

Publicis – photo credits: P.McLean, Recom, © Renault Marketing 3D-Commerce – July 2024.
Renault s.a.s, a French simplified joint stock company with a share capital of €533,941,113.00 / 122-122 bis avenue du Général Leclerc – 92100 Boulogne-Billancourt Cedex, France – registered on the Trade and Companies Registry (R.C.S.) of Nanterre under number B 780 129 987 / tel.: 0806 00 20 20.

CharPilakoutasgroup

77773344

www.pilakoutasgroup.com.cy

Nicosia Showroom: 18 - 20 Aristidou Street, 2370 Agios Dometios

Larnaca Showroom: 17 Eleftherias Avenue, 7102 Aradippou

Limassol Showrooms: 41 Theophanous Kritos, 4152 Kato Polemidia & 9 - 15 Andrea Kariolou Street, 4102 Agios Athanasios

Paphos Showroom: 43 Mesogis Avenue, 8280

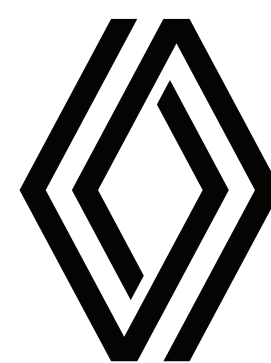

RENAULT

   renault.com.cy